

GX2 STEP MULTI-MOUNT INSTALLATION INSTRUCTIONS

PART NO'S: 147102 & 147101

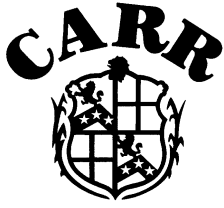

Quality and Style that Endures

Follow the Diagram below and the Written Directions on the back carefully for a proper, safe installations.

Should you encounter an unusual, unforeseen problem, contact our Technical Help Line

7:00 AM - 3:00 PM

Pacific Time

(951) 719-1068

www.CARR.com

©CARR PATTERN CO., INC.

THIS STEP FITS THE FOLLOWING VEHICLE:

FORD

'99 -'06 Super Duty all cabs/all doors/all series

'00 -'02 Excursion all doors

MATERIALS NEEDED: Drill motor, 3/8" drill bit, 1/4" drill bit, 1/8" drill bit, pencil, Phillips screw driver, center punch, two 1/2" wrenches, two 7/16" wrenches, silicone.

MATERIALS FURNISHED:

Two hardware packs, two step castings, four zinc plated steel brackets, instruction page.

**WAX YOUR STEP
ON A REGULAR
BASIS TO
MAINTAIN ITS
LUSTER!**

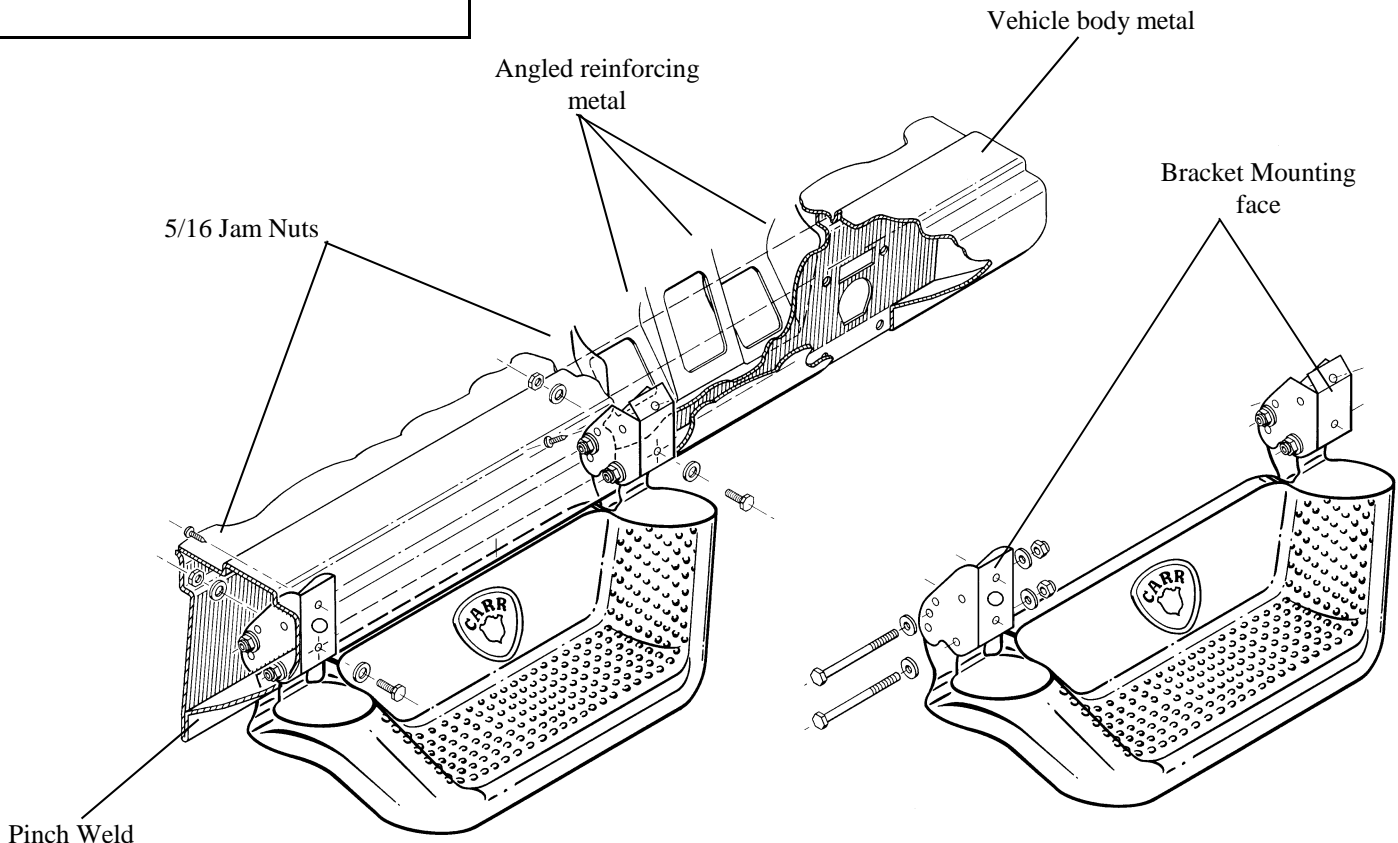

GX2 STEP MULTI-MOUNT INSTALLATION INSTRUCTIONS

PART NO'S: 147102 & 147101

WARNING: Do not over tighten nuts and bolts, or damage to the casting and or stripping of the threads could result.

WARNING: FOR SAFE AND PROPER USAGE OF THIS PRODUCT, THE MOUNTING INSTRUCTIONS MUST BE FOLLOWED CAREFULLY AND COMPLETELY.

IMPORTANT: The manufacturer and distributor of this product are in no way responsible for the consumer's failure to adhere to the warnings and directions of these instructions, in the event of damage to the consumer's vehicle, other properties and or personal injury.

1. For the proper position of the step, the front edge of the seat while in normal driving position should be in line with the center of the step. For personal preference or to avoid any obstruction underneath body metal, step can be moved left or right.
2. Assemble the steel brackets to the step as shown in the drawing, but only tighten with your fingers. **NOTE: Use the bracket with the double bends where the angled reinforcing metal is located on the vehicle.**
3. When positioning the step against the body metal be sure to avoid all bumps and screws to make sure that the step is against a flat surface.
4. Hold the step on your vehicle where you will mount the step. Position the step so that the bottom of the mounting face of the bracket is at the bottom of the edge of the pinch weld. (See diagram).
5. While holding the step in that position, take a pencil and use the bottom 5/16" holes on each bracket as a guide and mark the holes on the inside of the body metal. **Do not use larger center hole.**
6. Center punch the marked holes.
7. Take a 1/8" drill bit and drill out the centered punched holes.
8. Replace the 1/8" drill bit and drill out the 1/8" hole with a 3/8" drill bit.
9. After drilling, make sure that all the burrs are removed.
10. Remove the steel brackets from the step casting.
11. Place the steel brackets back on the vehicle where the two holes were drilled.
12. Use the 5/16" x 5/8" bolts with the 5/16" Jam nuts and 5/16" washers to securely tighten the brackets to the vehicle.
13. Place the step back into the steel brackets with the 1/4" hardware provided and securely tighten, making sure that the proper hole selection has been made.(See diagram)
14. Using the two 1/4" holes at the top of the step, take a 1/8" drill bit and drill holes into the body metal. Take the 5/8" sheet metal screws provided and securely tighten. Drilling at an angle may be necessary due to interference or for proper alignment.
15. Check again and securely tighten ALL hardware.
16. We advise putting silicone sealer around the areas where the aluminum mounting brackets contact the body metal.
17. After one month of use, go back and give all hardware a final tightening.

CARR PATTERN CO.,INC.

WARRANTY POLICY

FINISHES: Lifetime
STRUCTURAL WARRANTY: Lifetime

WARRANTY CONDITIONS:

- a. All warranties start from consumer's date of purchase.
- b. A new product will be sent out immediately to replace a warranty claim.

WARRANTY LIMITATIONS:

- a. Warranty coverage extends ONLY to repair or replacement of the CARR product. This warranty does not cover the cost of labor, transportation, installation or removal of the product.
- b. Warranty coverage does not extend to damage caused by: collision, fire, theft, freezing, vandalism, riot, explosion or object striking the product, or misuse of the product and/or the vehicle on which the product is being installed.
- c. Warranty coverage does not extend to damage caused by: airborne fallout (chemicals, tree sap, etc.), stones, hail, earthquake, water of flood, windstorm, lightning, the application of chemicals or sealants subsequent to manufacture.
- d. Warranty coverage does not extend to damages caused by: abuse, modification or improper installation of the product.
- e. Warranty coverage does not extend to any economic loss or extra expense including (without limitation), payment for the loss of time or pay, inconvenience, storage, loss of vehicle use, vehicle rental expense, equipment rental expense, lodging, meals, or other travel costs.

OTHER TERMS:

a. This warranty gives you specific legal rights and you may also have other rights that vary from state to state. CARR does not authorize any person to create for it any other obligation or liability in connection with its products. ANY IMPLIED WARRANTY OF MERCHANTABILITY OR FITNESS FOR A PARTICULAR PURPOSE APPLICABLE TO THIS PRODUCT IS LIMITED IN DURATION TO THE DURATION OF THIS WRITTEN WARRANTY. PERFORMANCE OF REPAIRS AND NEEDED ADJUSTMENTS IS THE EXCLUSIVE REMEDY UNDER THIS WRITTEN WARRANTY OR ANY IMPLIED WARRANTY. CARR SHALL NOT BE LIABLE FOR INCIDENTAL OR CONSEQUENTIAL DAMAGES RESULTING FROM BREACH OF THIS WRITTEN WARRANTY.*

* Some states do not allow limitations on how long an implied warranty will last or the exclusion or limitation of incidental or consequential damages, so the above limitations or exclusions may not apply to you.
GUARANTEE: Every attempt has been made to manufacture and distribute the finest quality products available. Our manufactured products are guaranteed to be free of defects due to workmanship or materials. Distributed products are subject to manufacturer's warranty only.

CARR- 27447 BOSTIK COURT, TEMECULA, CA 92590